

## Materiale per l'installazione incluso

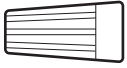

## Strumenti richiesti

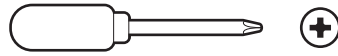

Cacciavite con punta a croce

## Installazione

### 1.

Interrompere l'alimentazione dal quadro elettrico.

**NOTA:** in caso di dubbi sull'interruttore da disattivare, spegnere l'interruttore principale o contattare un elettricista.

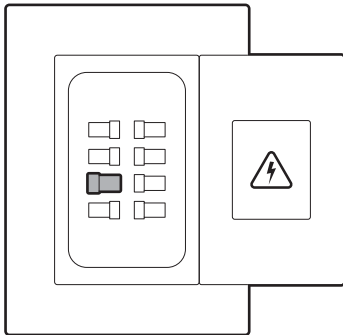

### ATTENZIONE!

Durante il processo di installazione si maneggeranno fili elettrici. Se non si è a proprio agio o non si ha esperienza, consultare un elettricista certificato.

### 2.

Rimuovere il coperchio del campanello del citofono.

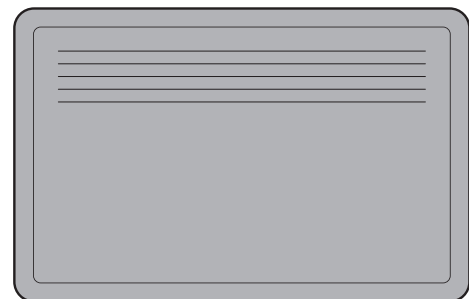
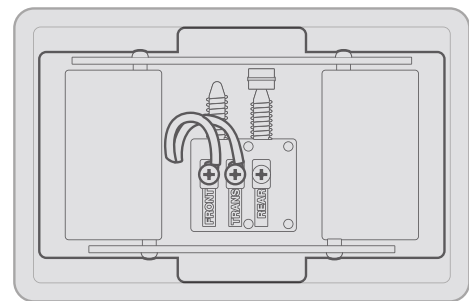

3.

Scollegare i fili collegati al campanello.

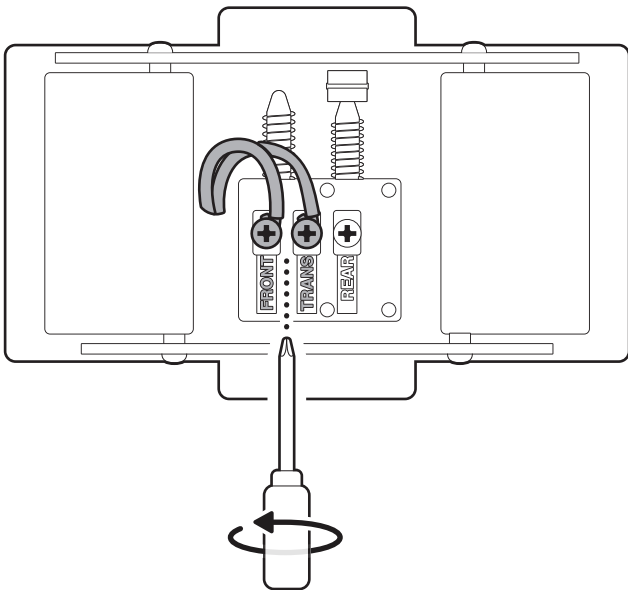

4.

Utilizzare il dado per cavo incluso per collegare i fili tra loro.

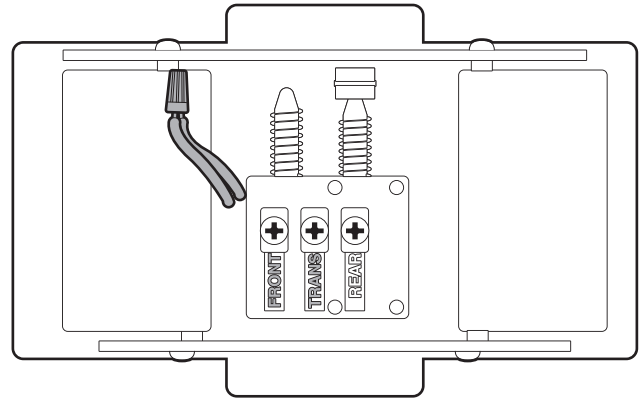

5.

Riposizionare il coperchio del campanello.

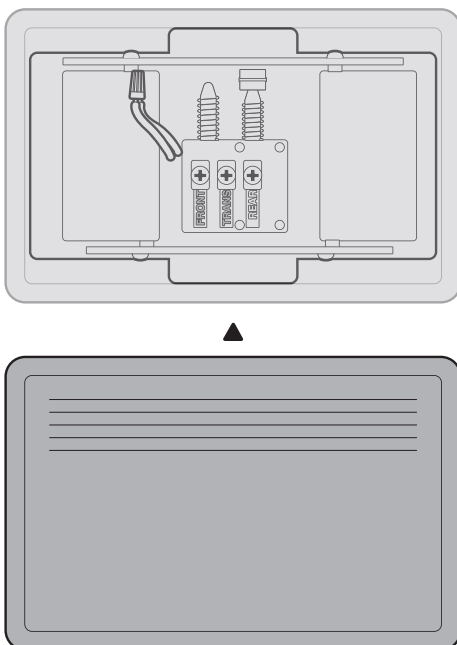

6.

Individuare il trasformatore per citofono esistente.

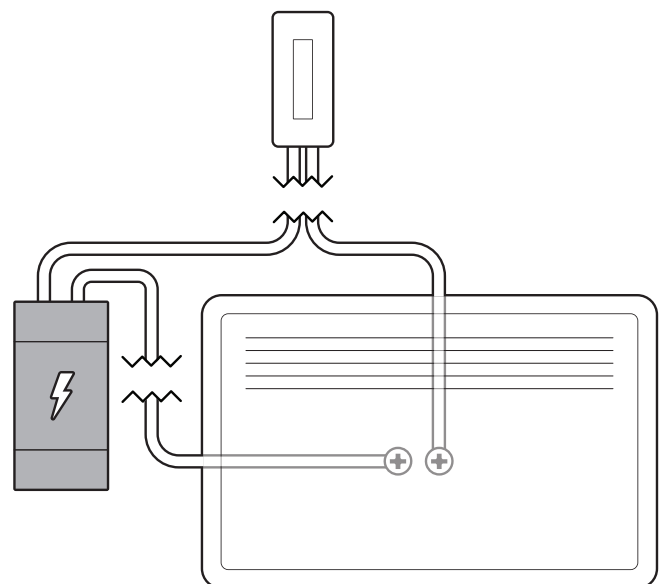

(Facoltativo) Rimuovere il trasformatore dal suo alloggiamento.

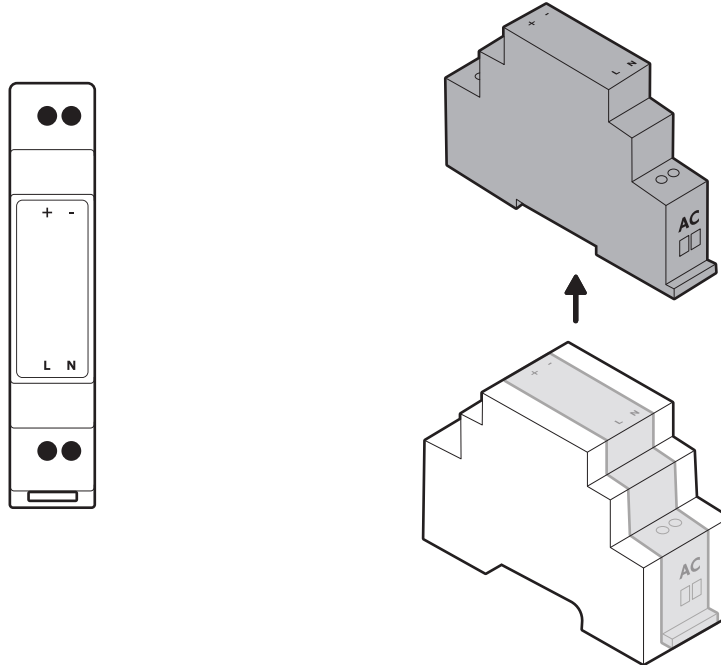

7.

Installare il trasformatore incluso.

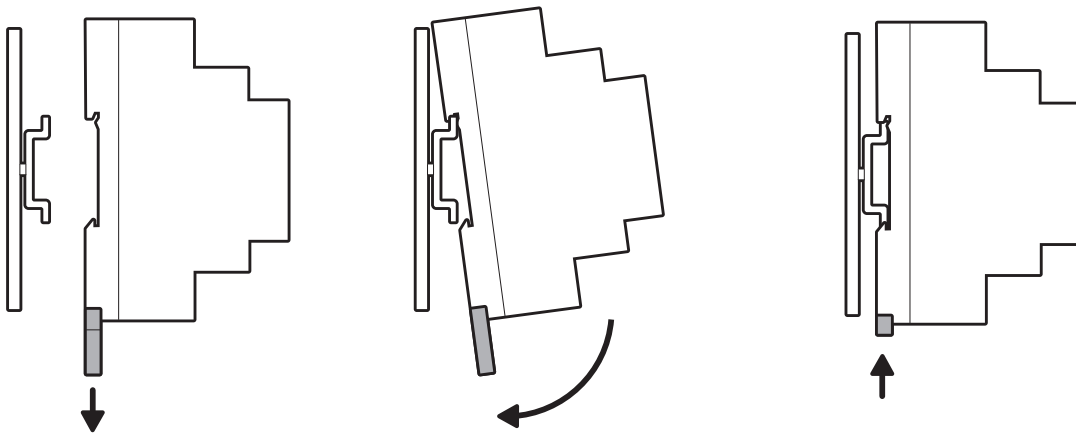

## 8.

Collegare l'alimentazione ai terminali L e N nella parte inferiore e il citofono ai terminali positivo e negativo (i fili del citofono possono essere collegati a entrambi i terminali).

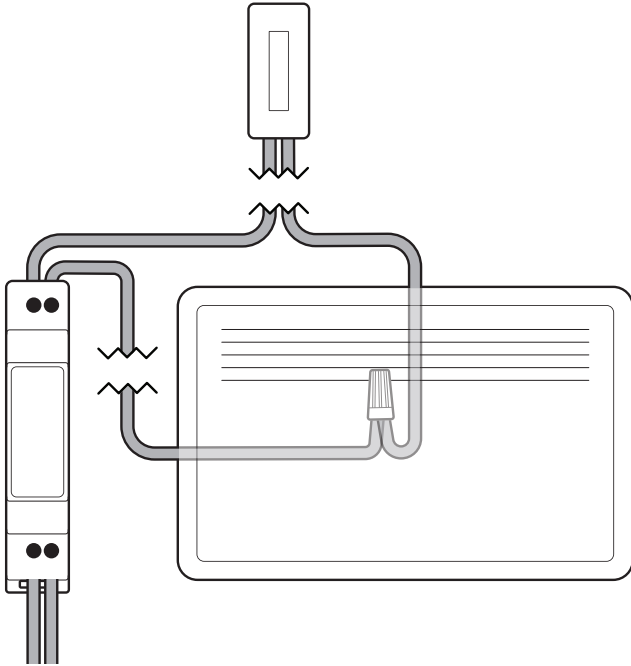

## 9.

Fare riferimento alla guida all'installazione del videocitofono per completare la configurazione.

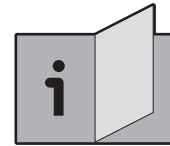

[ring.com/contact](https://ring.com/contact)



[ring.com/help](https://ring.com/help)

Ring LLC 12515 Cerise Ave, Hawthorne, CA, 90250 USA

Ring LLC / Amazon EU S.à.r.l., 38 Avenue John F. Kennedy, L-1855  
Luxembourg / Amazon UK, 1 Principal Place, Worship Street,  
London, EC2A 2FA, United Kingdom

アマゾンジャパン合同会社〒153-0064 東京都目黒区下目黒1-8-1

شركة Ring LLC طريق سيريس مبنى 12515 مدينة هاولتون، كاليفورنيا،  
الولايات المتحدة الأمريكية، 90250

©2025 Ring LLC or its affiliates. Ring and all related  
marks are trademarks of Ring LLC or its affiliates.

©2025 Ring LLC又はその関連会社。Ring及びこれらに関するすべての商標  
は、Ring LLC又はその関連会社の商標です。

