

Hardware included

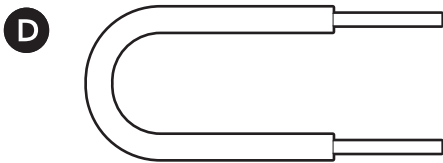

Tools needed

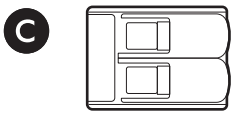
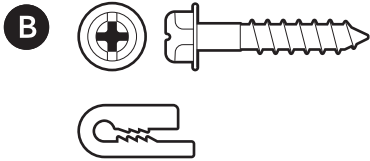
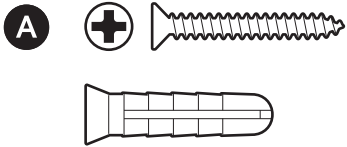
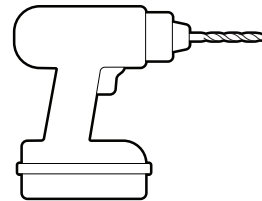
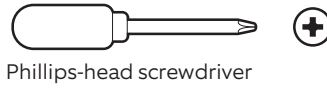

Drill with a 1/4 in (6 mm) masonry bit (optional)

1.

Remove the protective wrap.



2.

Download the Ring app.



3.

Scan the QR code on your device.

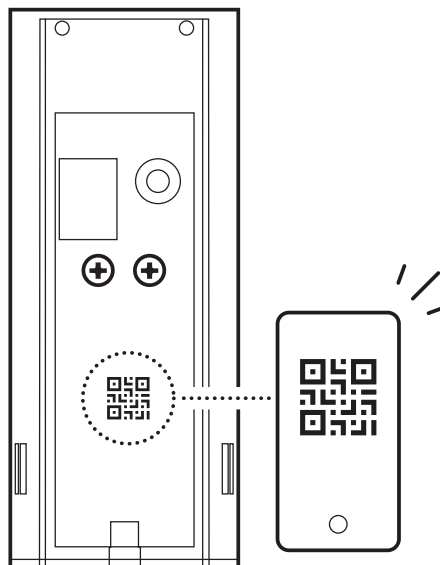

Doorbell installation

PLUG-IN ADAPTER FOR INDOOR USE ONLY

1.

Choose a location for your doorbell.

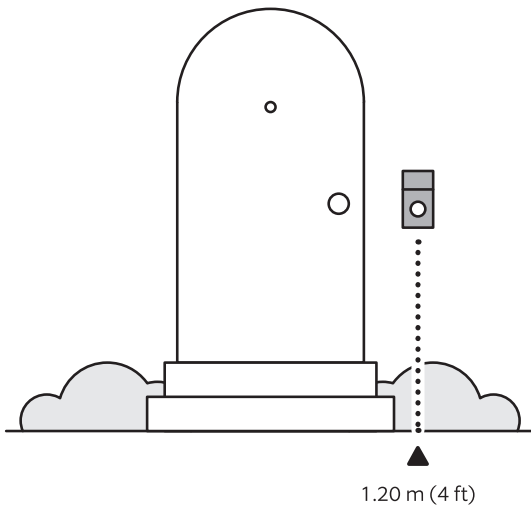

2.

Without plugging in the power adapter, run the power cable from the indoor outlet to the location you're installing your doorbell.

NOTE: Use an indoor outlet close to the install location.

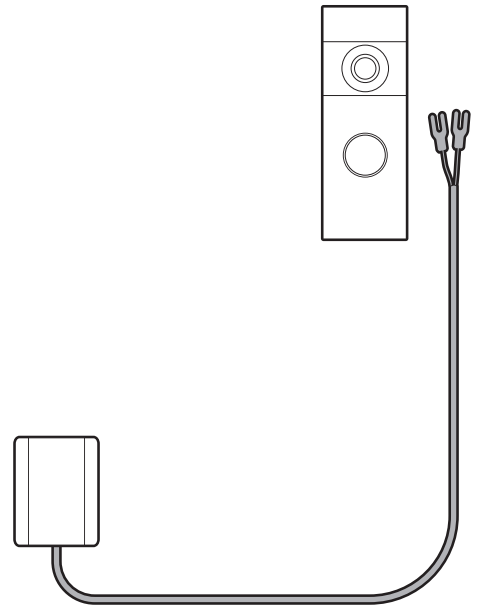

3.

Secure the power cable with the included cable clips.

NOTE: If running the cable through a wall, door, or window, exercise caution for electrical wiring and pipes when drilling.

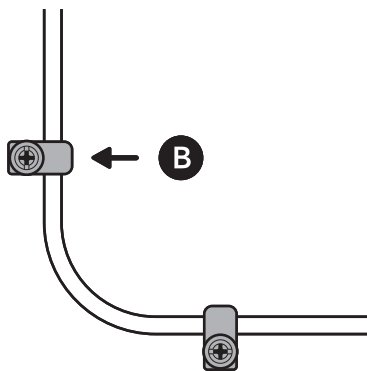

4.

Use the mounting bracket as a guide to mark screw holes on the wall.

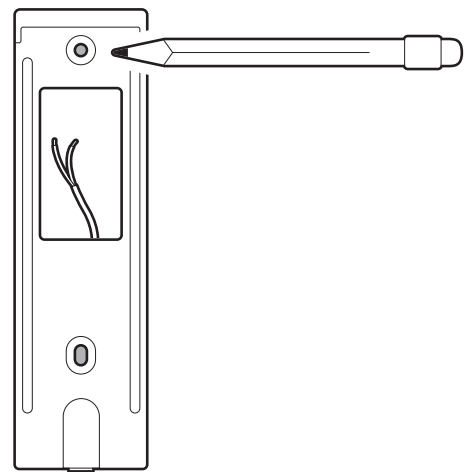

5.

Install the mounting bracket with the included screws.

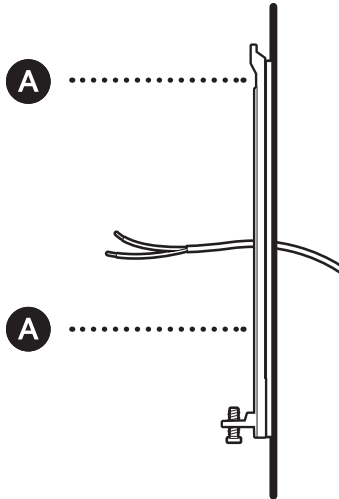

NOTE: On stucco, brick, or concrete, use a 1/4 in (6 mm) masonry bit to drill holes for the included wall anchors.

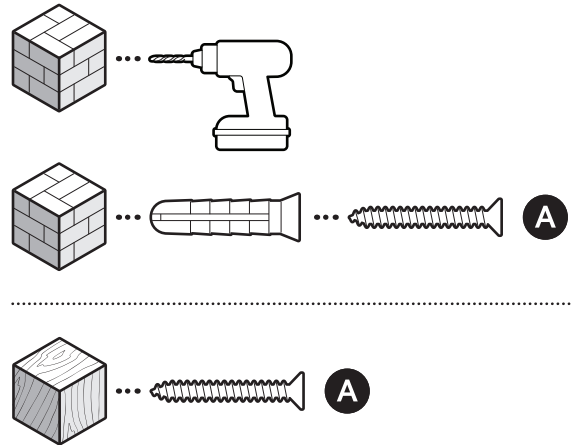

6.

Connect the power cable to your doorbell's wire terminals, ensuring the terminal wires are not in contact with each other.

NOTE: You can attach any wire to any terminal.

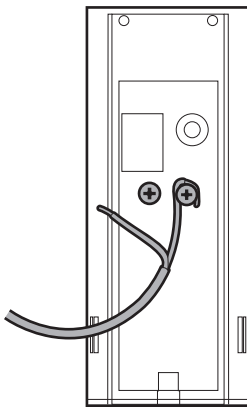

7.

Mount your doorbell by hooking it over the bracket and pushing down.

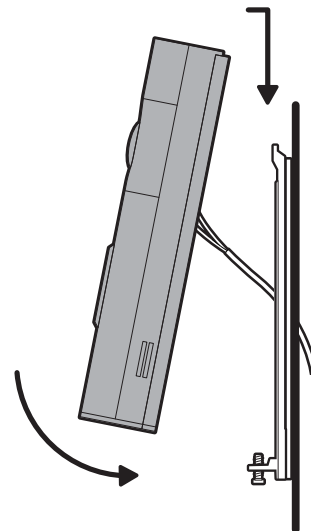

8.

Tighten the security screw.

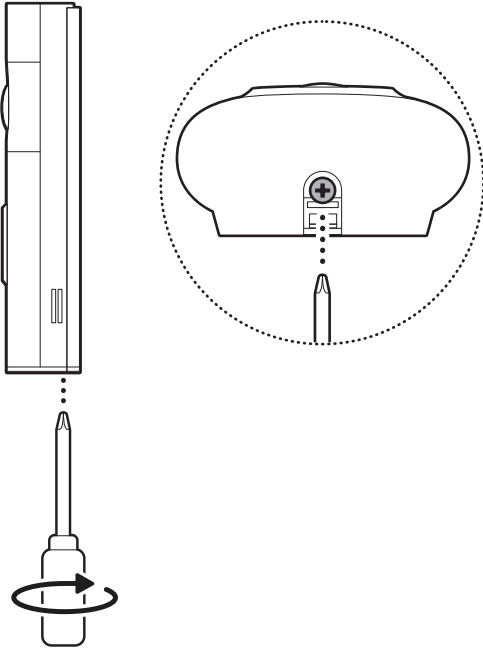

9.

Plug in the power adapter.

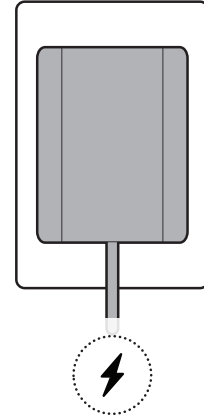

10.

Ring your doorbell to ensure everything is properly connected.

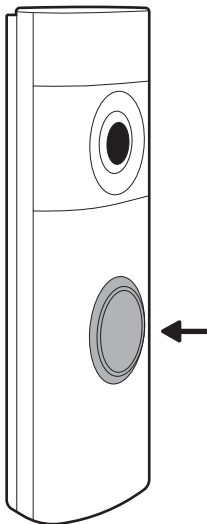

 ring.com/contact

 ring.com/help