

Hardware included

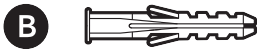

Tools needed

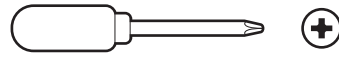

Phillips-head screwdriver

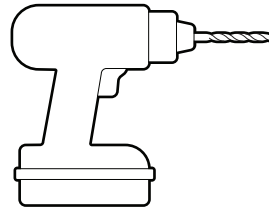

Drill with a 1/4 in (6 mm) masonry bit (optional)

1.

Remove the protective wrap.



2.

Download the Ring app.



3.

Remove the back cover and scan the QR code.

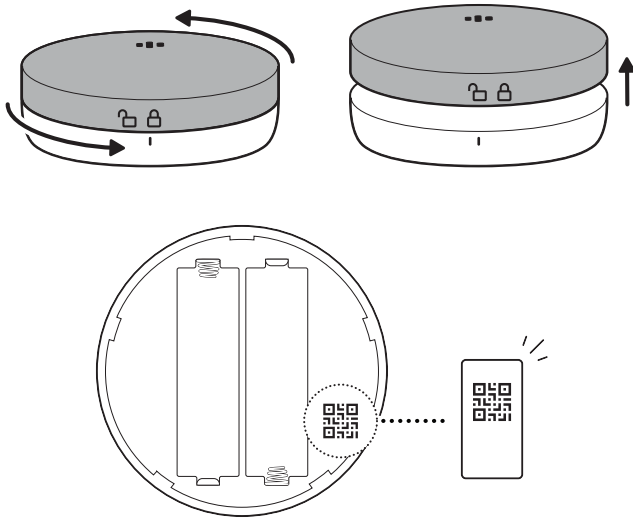

4.

Reattach the back cover by twisting until the line on your device aligns with the lock icon.

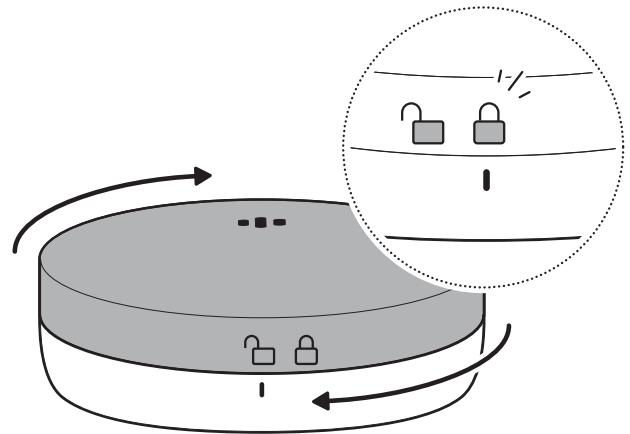

5.

Follow in-app setup.

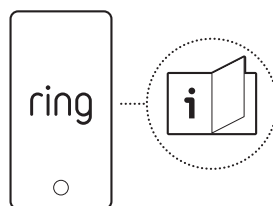

Installation

1.

Choose a location near leak-prone, hard-to-reach areas.

NOTE: Depending on temperature and humidity, the rope sensor may take up to 60 minutes to dry after water contact.

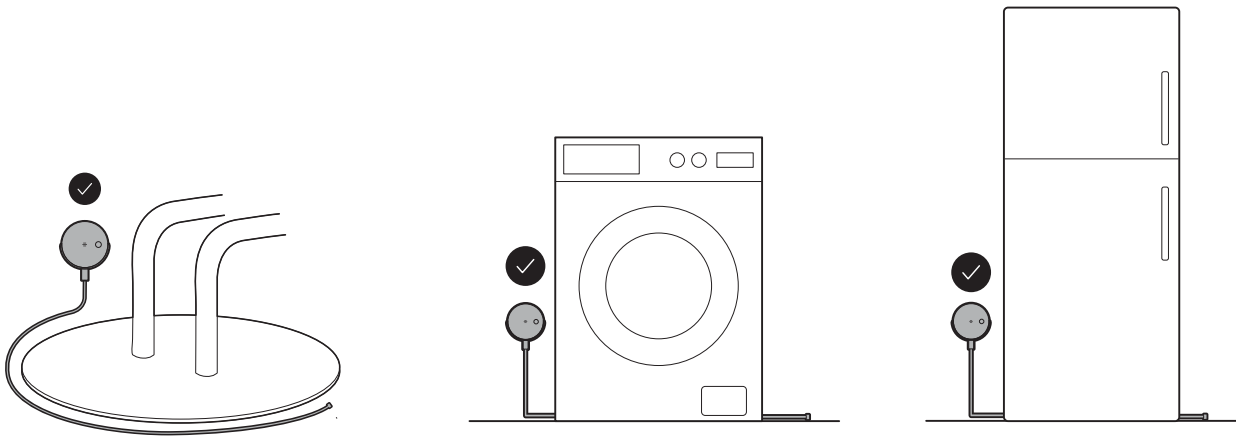

2.

(Optional) Install the mounting bracket on the floor or wall with the included screws or adhesive backing.

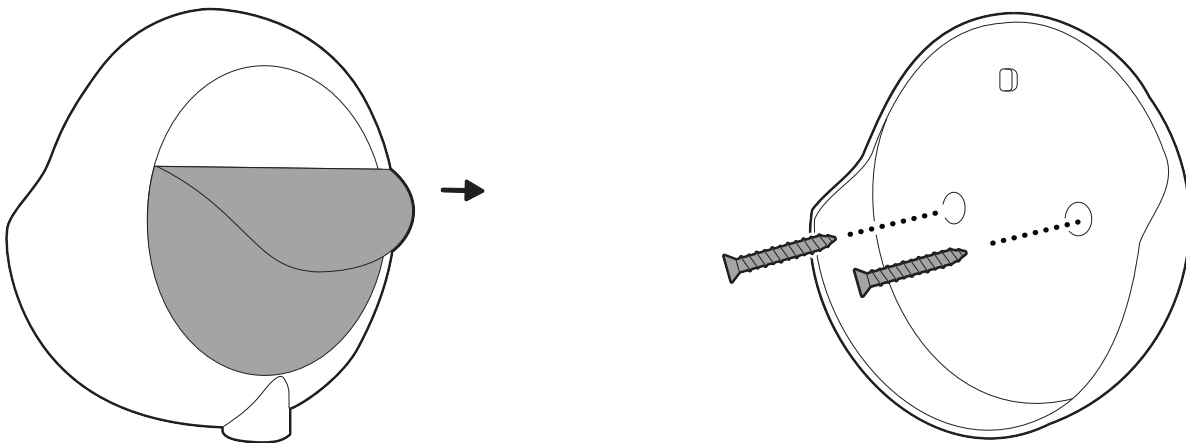

On drywall, stucco, brick, or concrete, use a 3/16 (5 mm) masonry bit to drill holes for the included wall anchors.

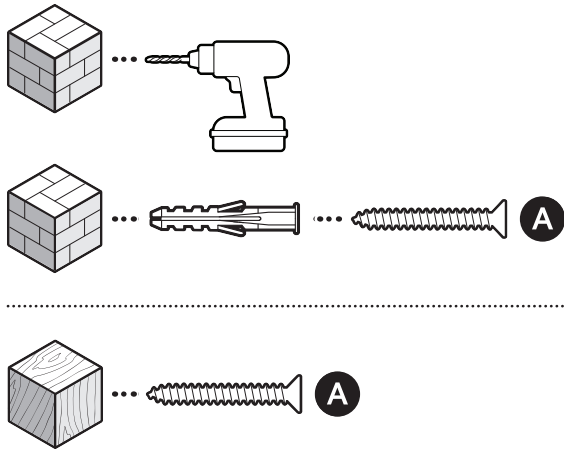

4.

Insert the included cable into the hole on the mounting bracket.

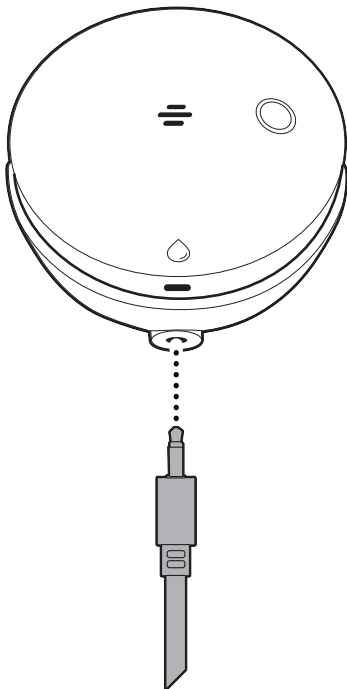

3.

Attach your monitor to the mounting bracket by sliding until you hear a snap to secure.

NOTE: Ensure the monitor is pointing up.

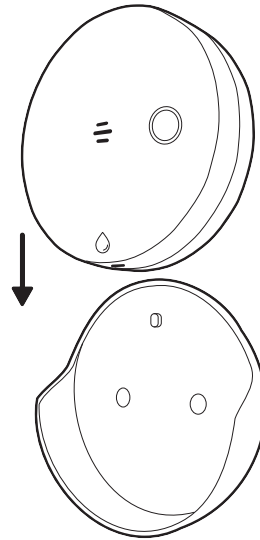

5.

Route the other end of the cable over the area where you want to detect water, like a sump pump basin.

CAUTION!

Do not submerge the main unit or mounting bracket in any liquid.

NOTE: Depending on temperature and humidity, the rope sensor may take up to 60 minutes to dry after water contact.

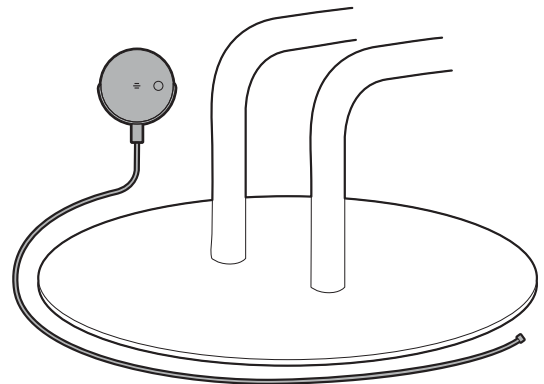

Amazon Sidewalk-enabled device; requires Amazon Sidewalk coverage for use. Coverage may vary by location. For Amazon Sidewalk information, visit ring.com/sidewalk



ring.com/contact



ring.com/help