

Hardware included

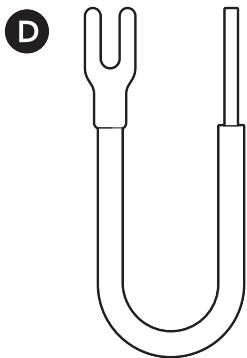

Tools included

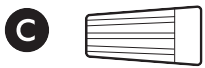
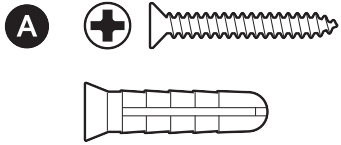

Removal tool

Tools needed

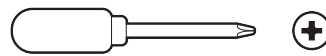

Phillips-head screwdriver

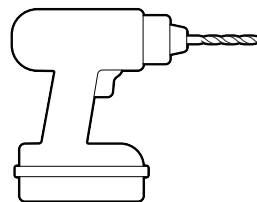

Drill with a 1/4 in (6 mm) masonry bit (optional)

1.

Download the Ring app.



2.

Scan the QR code.

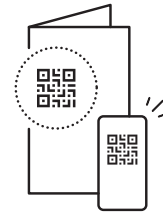

3.

Remove the protective wrap.



Doorbell installation

1.

Shut off power at the breaker.

NOTE: If you are unsure which breaker to flip, turn off the master breaker or contact an electrician.

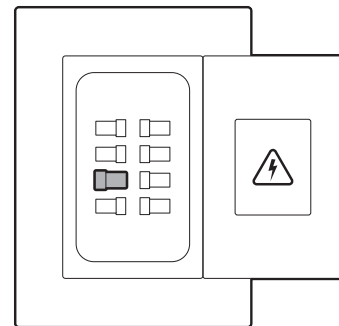

CAUTION!

You'll be working with electrical wires during the install process. If you encounter damaged or unsafe wiring, or if you are unsure, uncomfortable, or inexperienced, please consult with a licensed electrician.

2.

Remove your doorbell chime's cover.

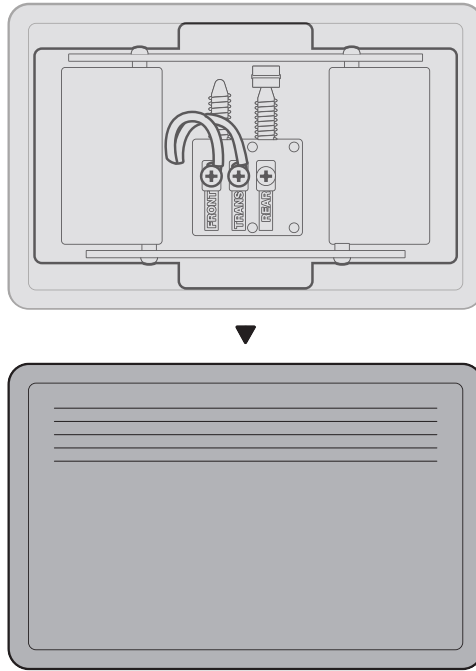

3.

Disconnect the wires attached to your chime.

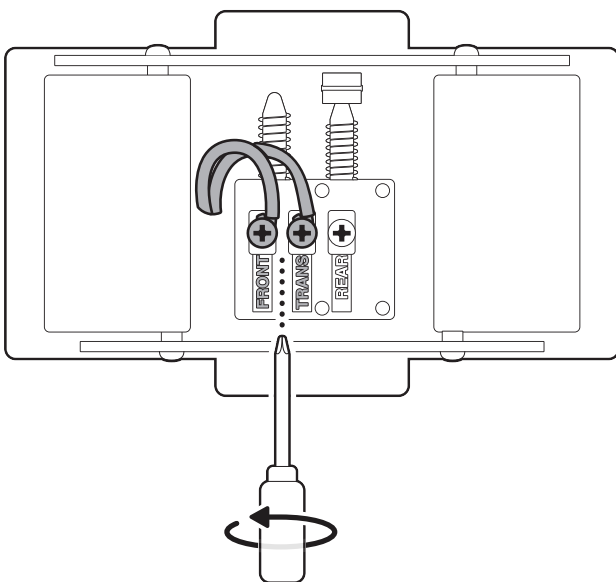

4.

Use the included wire nut to connect the wires together.

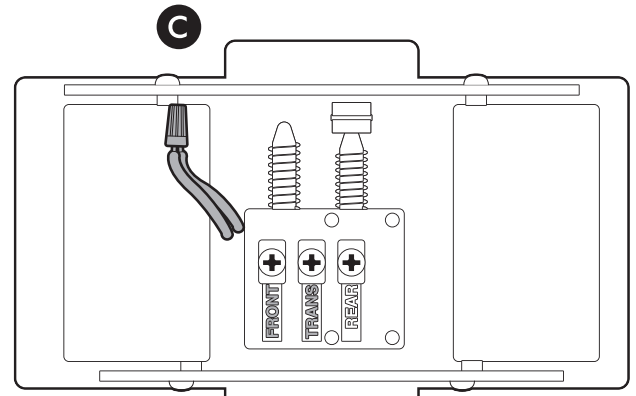

5.

Re-attach your chime's cover.

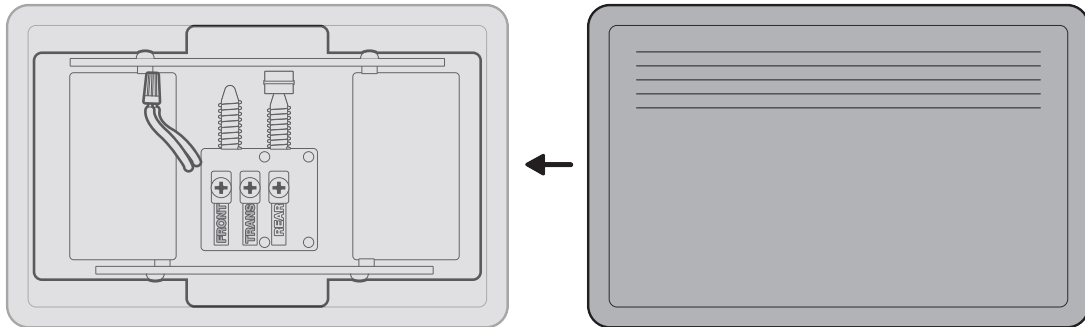

6.

Locate the existing doorbell transformer.

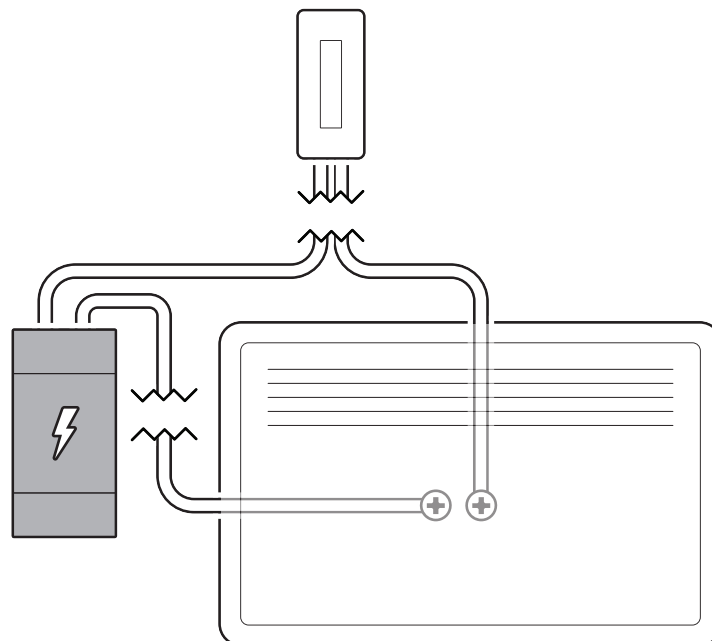

7.

Install the included transformer.

(Optional) Remove the transformer from its housing unit.

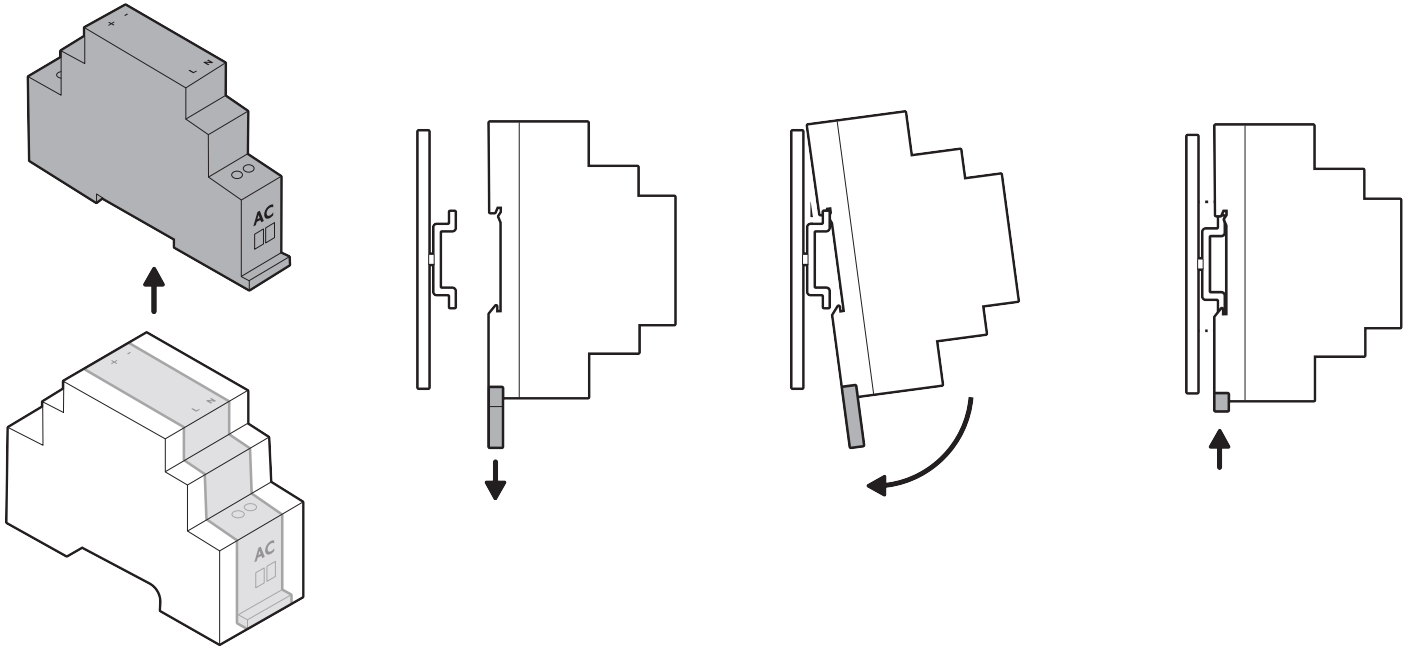

8.

Connect power to the bottom L & N terminals and the doorbell to positive & negative terminals (doorbell wires can go in either terminal).

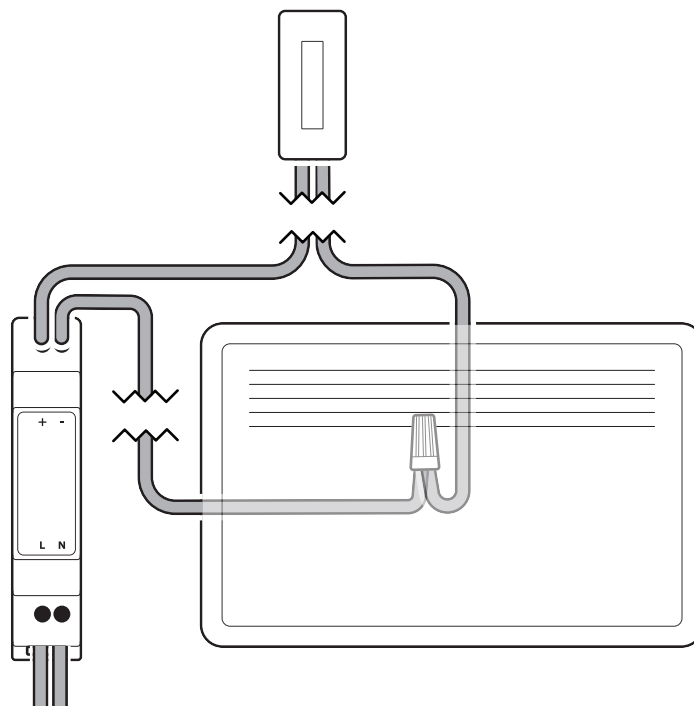

9.

(Optional) If using a corner mount, install the mount over your doorbell wires using the large oval holes, ensuring it is facing in your desired viewing direction.

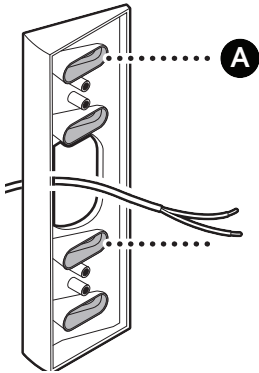

On stucco, brick, or concrete, use a 6 mm (1/4 in) masonry bit to drill holes for the included wall anchors.

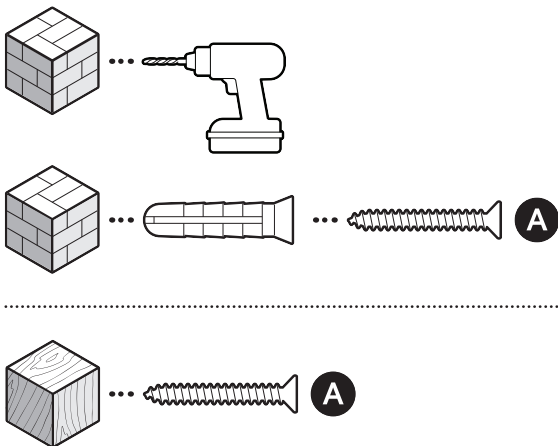

(Optional) If using a wedge mount, install the mount over your doorbell wires using the screws included with your wedge kit, ensuring it is facing down.

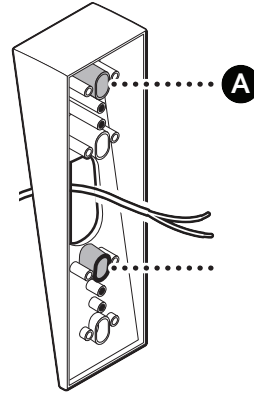

On stucco, brick, or concrete, use a 6 mm (1/4 in) masonry bit to drill holes for the included wall anchors.

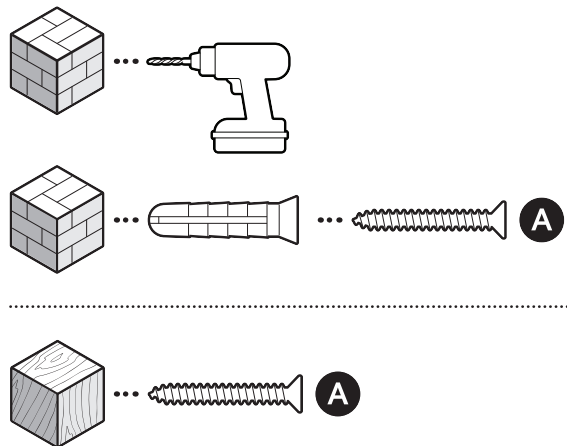

10.

(Optional) If installing multiple wedge or corner mounts, insert screws through both mounts to hold them together.

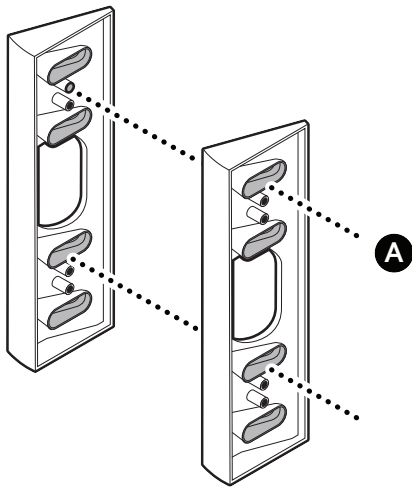

11.

Install the mounting bracket on your mount or directly over the doorbell wiring with the included screws.

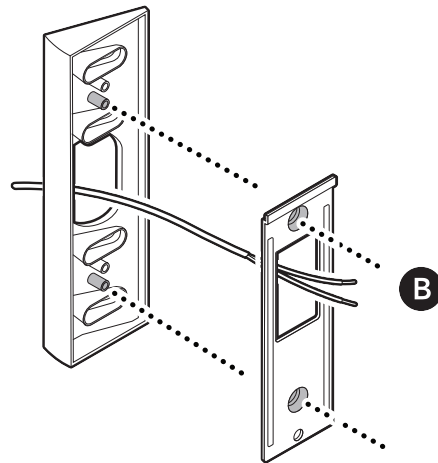

12.

Remove your doorbell's faceplate by inserting the removal tool into the slot at the bottom of your doorbell.

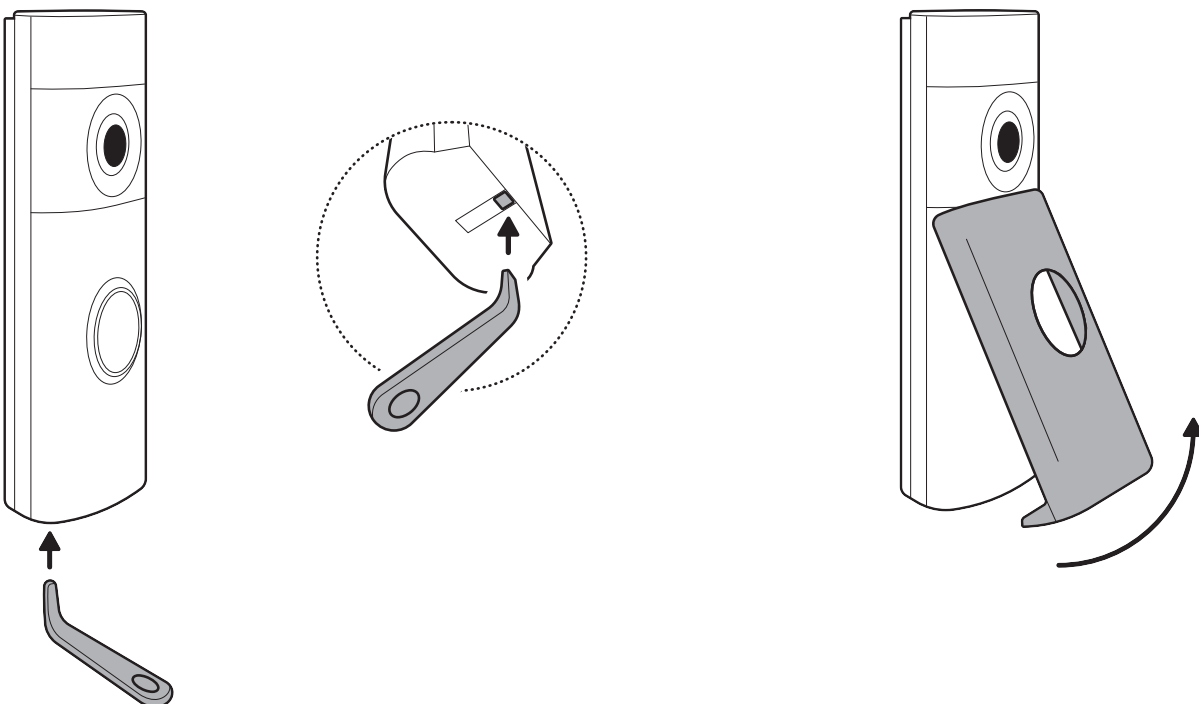

13.

Attach the included fork connectors to your doorbell wiring with wire nuts.

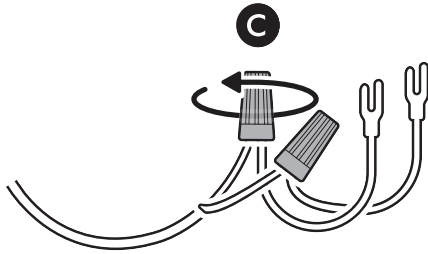

14.

Connect the fork connectors to your doorbell's wire terminals.

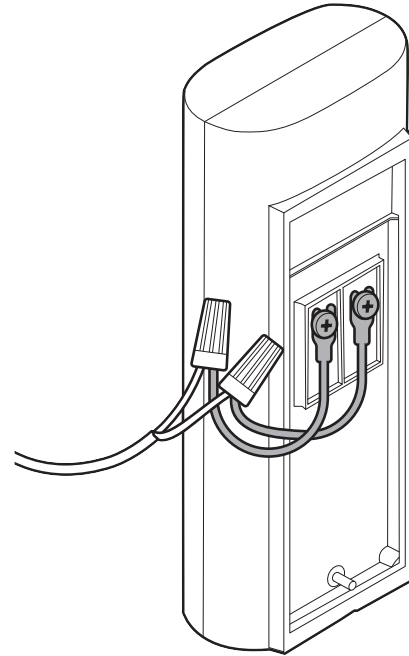

15.

Mount your doorbell by hooking it over the bracket and pushing down.

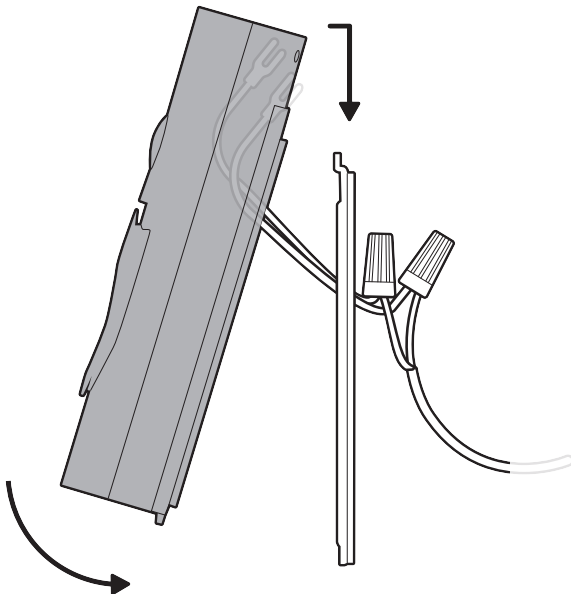

16

Tighten the security screw.

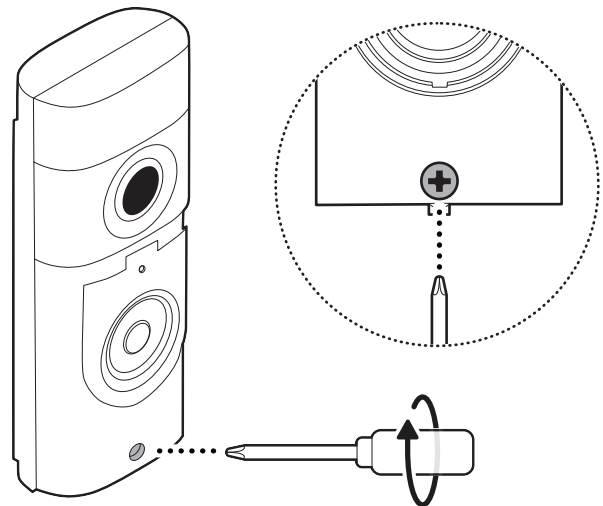

17.

Restore power at the breaker.

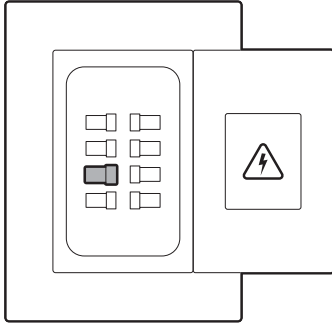

18.

Ring your doorbell to ensure everything is properly connected.

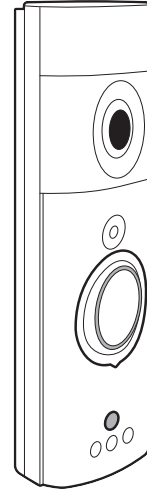

19.

Reattach the faceplate.

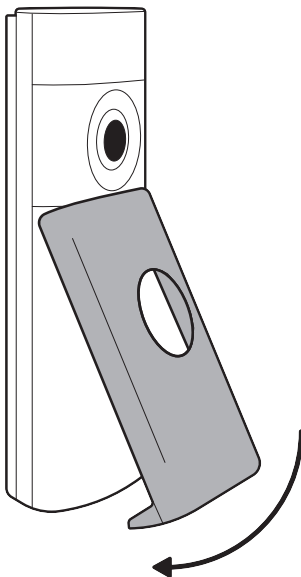
ring.com/contactring.com/help

Ring LLC 12515 Cerise Ave, Hawthorne, CA, 90250, USA

Ring LLC / Amazon EU S.à.r.l., 38 Avenue John F. Kennedy, L-1855 Luxembourg / Amazon UK, 1 Principal Place, Worship Street, London, EC2A 2FA, United Kingdom

شركة Ring LLC طريق سيريس مينغ 12515 مدينة هاوثورن، كاليفورنيا، 90250، الولايات المتحدة الأمريكية

©2025 Ring LLC or its affiliates. Ring and all related marks are trademarks of Ring LLC or its affiliates.