

ring Wired Doorbell Pro



1

 ring.com/manuals

Download the full manual online.
Téléchargez le manuel complet en ligne.
Laden Sie das vollständige Handbuch online herunter.
Scarica il manuale completo online.
Descarga el manual completo en línea.
Download de volledige handleiding online.
Last ned hele håndboken på nett.
Ladda ner hela handboken online.
Lataa kokonainen opas verkosta.
Download hele vejledningen online.

ring

 ring.com/help

 +44 1727 26 3045

 +800 8700 9781

Ring LLC / Amazon EU S.à.r.l., 38 Avenue
John F. Kennedy, L-1855 Luxembourg /
Amazon UK, 1 Principal Place, Worship
Street, London, EC2A 2FA, United Kingdom

© 2024 Ring LLC or its affiliates.
Ring and all related marks are trademarks
of Ring LLC or its affiliates.



2

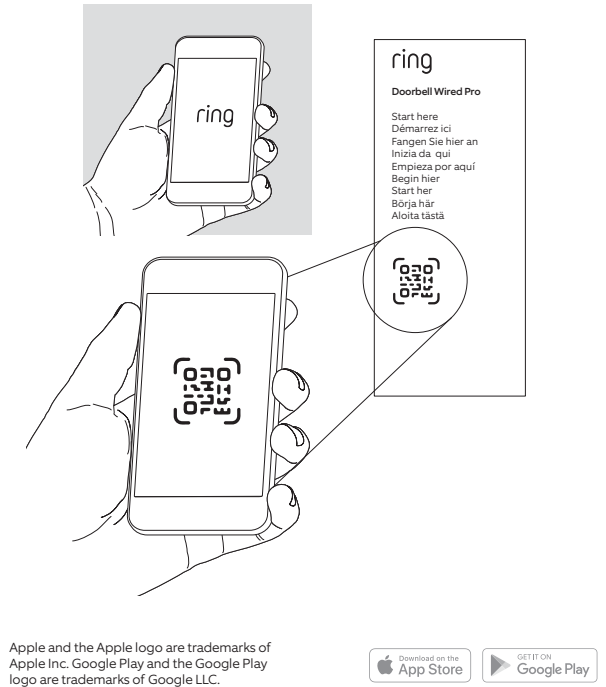

Apple and the Apple logo are trademarks of
Apple Inc. Google Play and the Google Play
logo are trademarks of Google LLC.



3

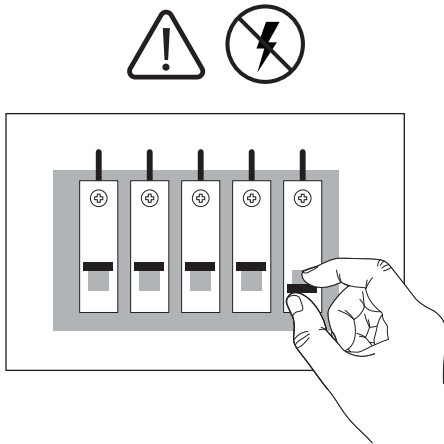

Warning: Professional installation Recommended. Turn off the power to your existing doorbell first. / Avertissement : installation professionnelle recommandée. Mettez d'abord votre sonnette existante hors tension. / Warnung: Installation durch einen Elektrofachmann empfohlen. Schalten Sie zuerst die Stromzufuhr zu Ihrer bestehenden Türklingel aus. / Attenzione: si consiglia l'installazione professionale. Innanzitutto, disattiva l'alimentazione del citofono in uso. / Advertencia: se recomienda instalación profesional. Desconecta la alimentación del timbre primero. / Let op: we bevelen installatie door een professional aan. Schakel eerst je oude deurbel spanningsvrij. / Advarsel: Professionell installasjon anbefales. Slå av den eksisterende ringeklokken først. / Varning: Professionell installation rekommenderas. Stäng först av strömmen till din befintliga dörrklocka. / Varoitus: Suosittelemme, että asennuksen tekee ammattilainen. Katkaise ensin virta nykyisestä ovikellostasi. / Advarsel: Professionell installation anbefales. Sluk for strømmen til din eksisterende dørklokke først.

4

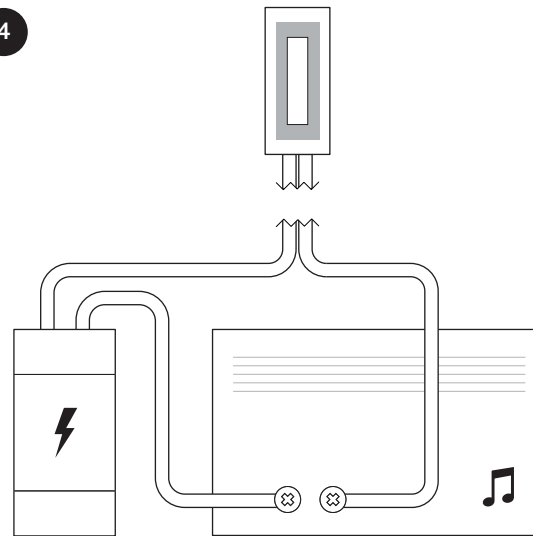

Locate your existing doorbell chime and power transformer. / Localisez le carillon de votre sonnette existante et le transformateur de puissance. / Lokalisieren Sie Ihre bestehende Türklingel und Ihren Transformator. / Individua il chime del citofono in uso e il trasformatore di corrente. / Ubica el timbre y el transformador eléctrico existentes. / Pak je oude deurbel en de stroomtransformator erbij. / Finn den eksisterende ringeklokken og strømtransformatoren. / Lokalisera transformatorn till din befintliga dörrklocka. / Etsi nykyisen ovikellon kello ja muuntaja. / Find din eksisterende dørklokke og strømtransformer.

5

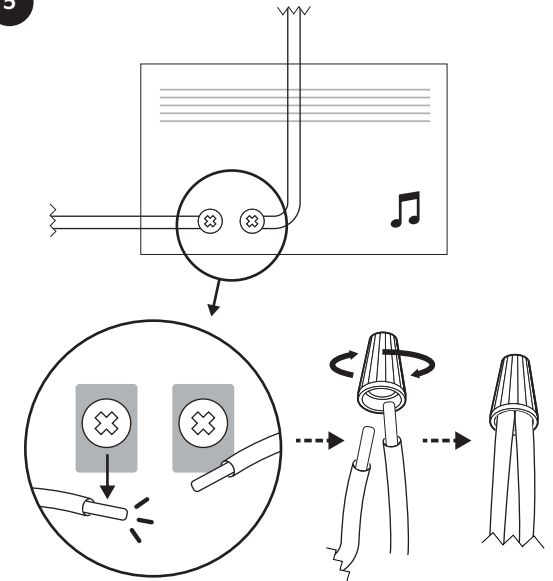

Bypass your existing chime. / Ignorez votre carillon existant. / Umgehen Sie Ihre bestehende Klingel. / Ignora il chime in uso. / Puntea el timbre existente. / Ontkoppel je oude deurbel. / Forbikoble den eksisterende ringeklokken. / Kringgå din befintliga klocka. / Ohita nykyinen kello. / Frakobl din eksisterende ringeklokke.

6

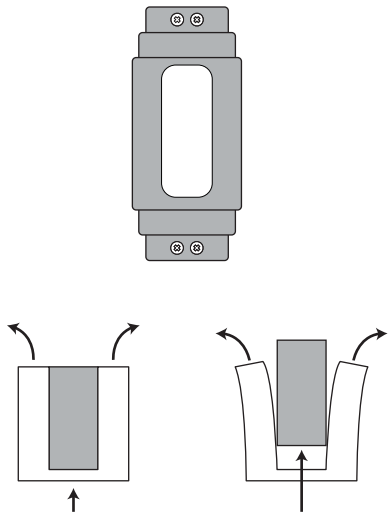

Depending on your transformer size, remove the transformer from its housing unit. / Selon la taille de votre transformateur, retirez le transformateur de son boîtier. / Je nach Größe des Transformators, entfernen Sie den Transformator aus seinem Gehäuse. / A seconda delle dimensioni del trasformatore, rimuovilo dall'alloggiamento. / En función del tamaño del transformador, quítalo de la carcasa. / Afhankelijk van de grootte van je transformator moet je deze uit de behuizing verwijderen. / Avhengig av størrelsen på transformatoren må du fjerne den fra hovedenheten. / Beroende på transformatorns storlek tar du bort transformatorn från höljenheten. / Poista muuntaja kotelostaan riippuen sen koosta. / Afhängigt af transformerens størrelse skal transformeren tages ud.

7

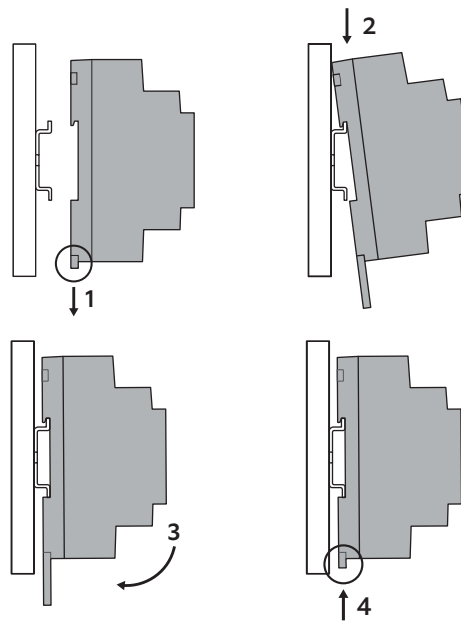

Replace your existing transformer with the new one. / Remplacez votre transformateur existant par le nouveau. / Tauschen Sie den bestehenden Transformator durch den neuen aus. / Sostituisci il trasformatore in uso con quello nuovo. / Reemplaza el transformador existente por uno nuevo. / Vervang de oude transformator door de nieuwe. / Skift ut den eksisterende transformatoren med den nye. / Byt ut den befintliga transformatorn mot den nya. / Laita uusi muuntaja vanhan tilalle. / Udskift den eksisterende transformator med den nye.

8

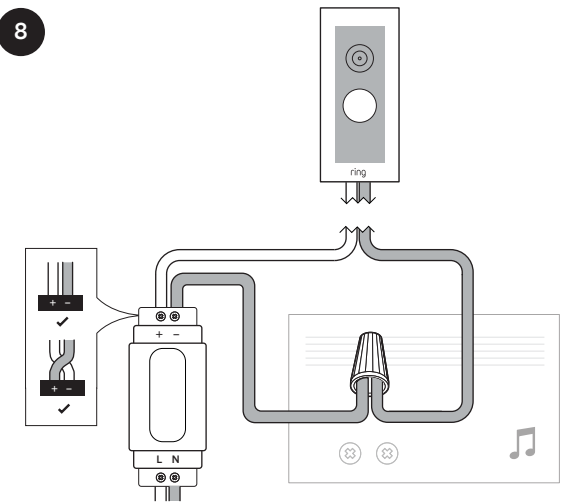

Connect power to the bottom L & N terminals and the doorbell to + & - (doorbell wires can go in either terminal). / Connectez l'alimentation aux bornes L et N inférieures et la sonnette au + et au - (les fils de la sonnette peuvent être reliés à l'une ou l'autre des bornes). / Schließen Sie daraufhin die Drähte an die unteren L- und N-Klemmen an und verbinden Sie die Türklingeldrähte mit + und - (Es spielt dabei keine Rolle, welcher Türklingeldraht an welche Klemme angeschlossen wird). / Collega l'alimentazione ai terminali L e N e al citofono + & - (i cavi del citofono possono essere collegati a entrambi i terminali). / Conecta la alimentación a los terminales inferiores L y N y el timbre a + & - (los cables del timbre pueden ir en cualquiera de los terminales). / Zet stroom op de onderste L- en N-aansluitingen. Sluit de deurbel aan op + en - (deurbeldraden kunnen op beide aansluitingen worden aangesloten). / Koble strømmen til terminalene L og N på undersiden og ringeklokken til + og - (ringeklokkeledningene passer i begge terminalene). / Anslut strømmen till de nedre L- och N-fästena och dörrklockan till + och - (dörrklockskablar kan anslutas till båda fästena). / Yhdistä virta alareunan L- ja N-napoihin ja ovikellon plus (+)- ja miinus (-) -liitäntöihin (ovikellon johdot voi liittää kumpaankin tahansa napaan). / Slut strømmen til de nederste L- og N-terminaler og dørrklokken til + og - (dørrklokkes kabler kan føres i ind begge terminaler).

6

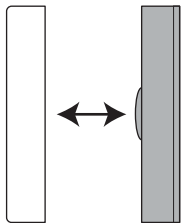
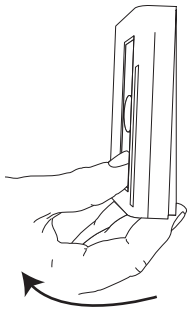

7

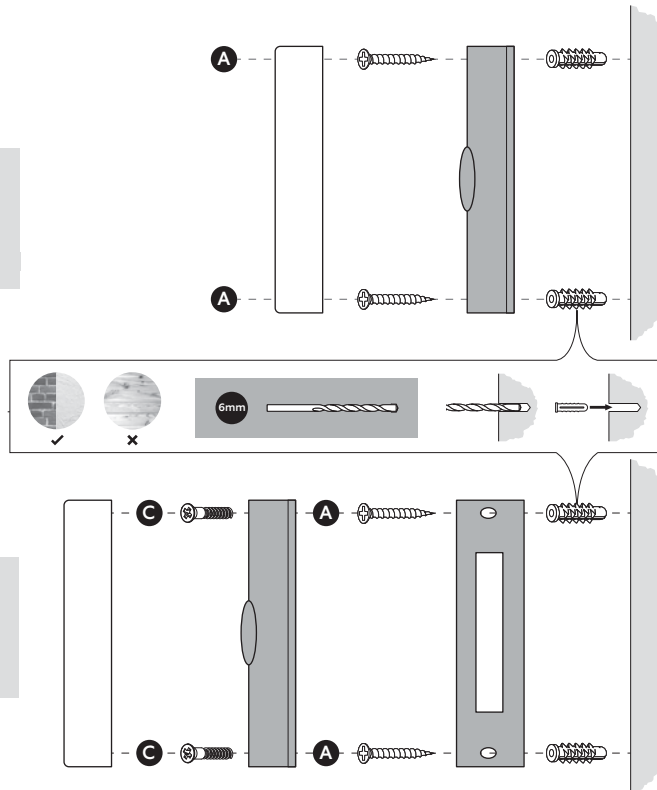
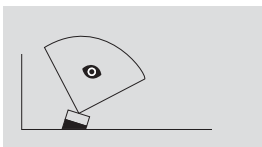
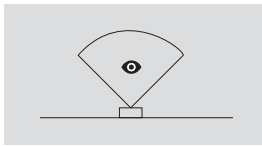

8

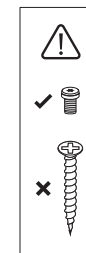
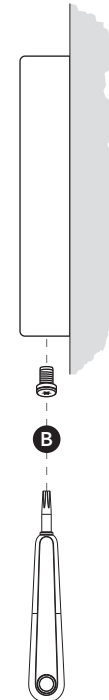

ring

Wired Doorbell Pro

Start here
Démarez ici
Fangen Sie hier an
Inizia da qui
Empieza por aquí
Begin hier
Start her
Börja här
Aloita tästä

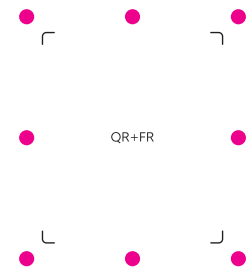

22-004520-03