



Plug-in Adapter (2nd Gen)



Safety and Compliance Information

Use Responsibly. Read all instructions and safety information before use.

SAFETY INFORMATION

FAILURE TO FOLLOW THESE SAFETY INSTRUCTIONS COULD RESULT IN INJURY

Small parts contained in the Plug-In Adapter kit may present a choking hazard to small children. Keep small parts away from children. Your Ring Plug-In Adapter should only be used in accordance with the instructions and intended purpose. Using this accessory in any way other than its intended purpose could cause injury to yourself, others or damage to the device. Your Ring Plug-In Adapter is not waterproof and as such should not be submerged in water, doing so could cause injury to yourself, others or damage to the device.



DANGER — TO REDUCE THE RISK OF FIRE OR ELECTRIC SHOCK, FOLLOW THESE INSTRUCTIONS CAREFULLY.

- Do not force the adapter into a power outlet.
- Do not expose the adapter or cable to liquids.
- If the adapter or cable appears damaged, discontinue use immediately.

Install your power adapter into an easily accessible socket-outlet located near the equipment that will be plugged into or powered by the adapter.

For device compatibility information, see the detail page for this adapter on Amazon.com.

Model No.: DSA-12PF16-24 240050
Power Input: 100-240VAC, 50/60Hz, 0.5A
Power Output: 24VDC, 0.5A, 12.0W

This device complies with Part 15 of the FCC Rules. Operation is subject to the following two conditions: (1) this device may not cause harmful interference, and (2) this device must accept any interference received, including interference that may cause undesired operation. Your device User Guide may contain additional safety warnings.

RECYCLING YOUR DEVICE PROPERLY

Make sure you dispose of, or recycle, your device in accordance with your local laws and regulations. For information about recycling your device, go to www.amazon.com/devicesupport.

1. Choose an outlet and cable path.

Select a power outlet near where your device will be located, and then choose a cable path to your device.

The cable can be run through your wall, or through a door or window, if desired.

Note: Don't plug the power adapter in yet!

2. Attach the wires

Attach the power wires to the terminals on the rear of your device.

* This Ring Video Doorbell is for illustration purpose only. Your Plug-In Adapter is compatible with various types of Ring Video Doorbells.

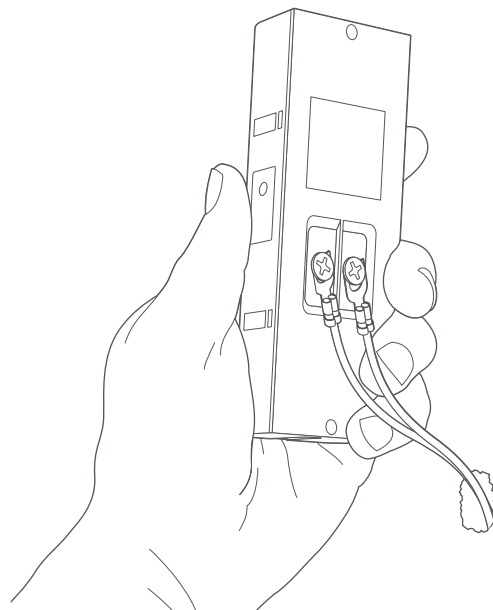

3. Plug in the power adapter.

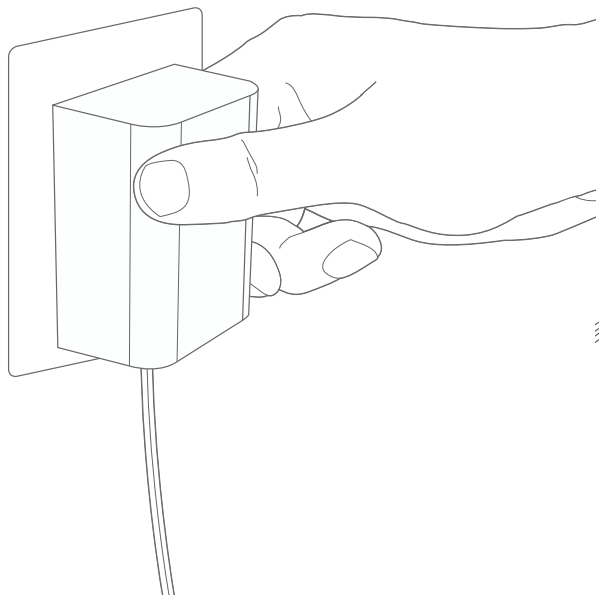

4. Fix the cable

Secure the cable to the wall with the provided cable clips.

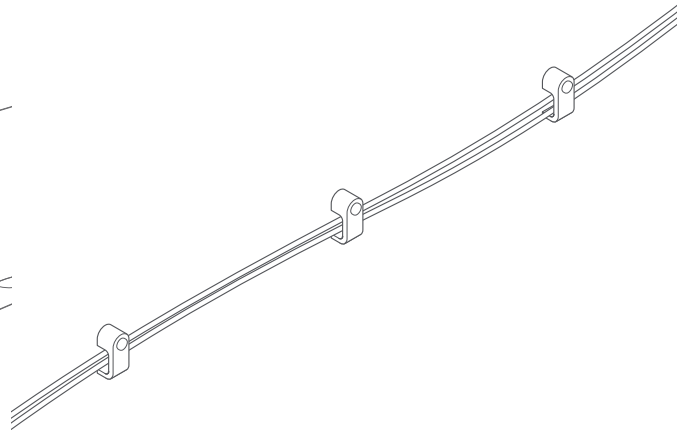

5. Install your Ring Doorbell.

If you haven't already, mount and set up your Doorbell according to the instructions provided with your device.

* This Ring Video Doorbell is for illustration purpose only. Your Plug-In Adapter is compatible with various types of Ring Video Doorbells.

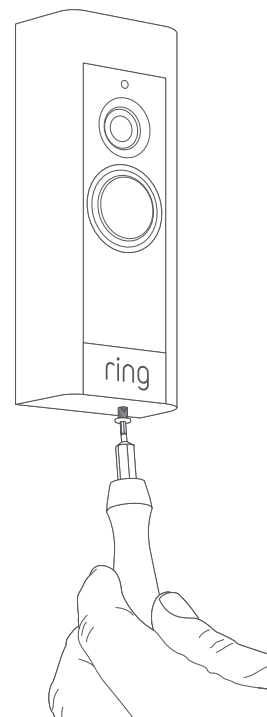

ring

1532 26th St
Santa Monica, CA 90404
USA

© 2020 Ring LLC or its affiliates.

Ring and all related logos are trademarks of Ring LLC or its affiliates.